

Startup Guide  
Sound Bar : HT-ST5000

What's in the box

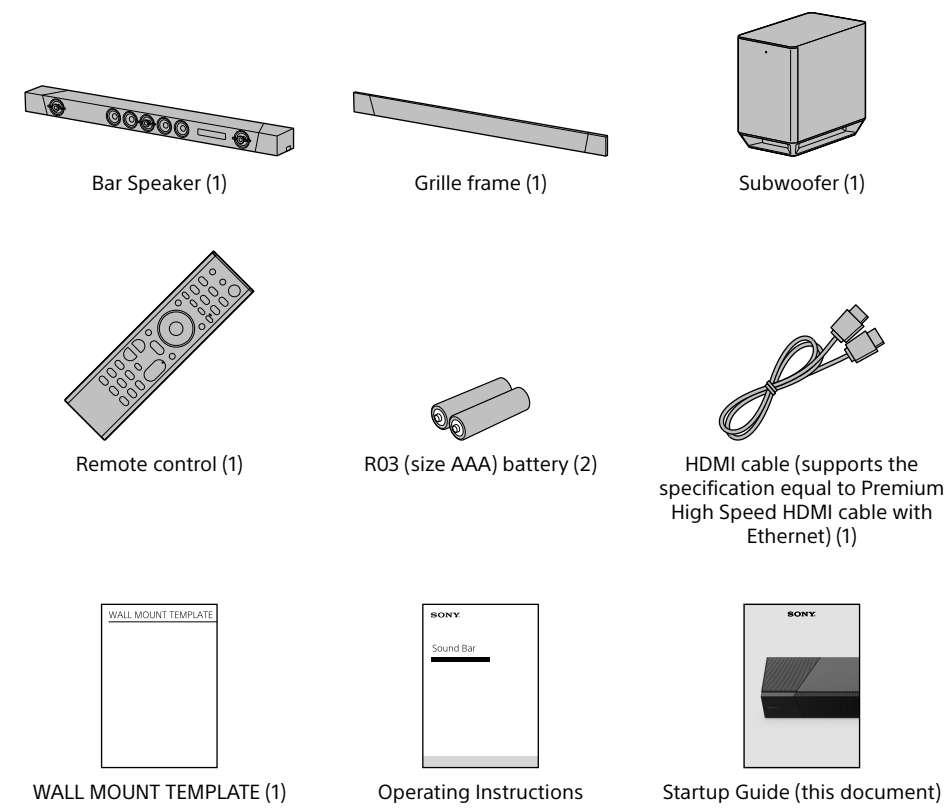

**About the operation method of the system**  
Connect this system and the TV with the HDMI cable (supplied) to display the operation screen of the system on the TV.

1 Deciding the installation position

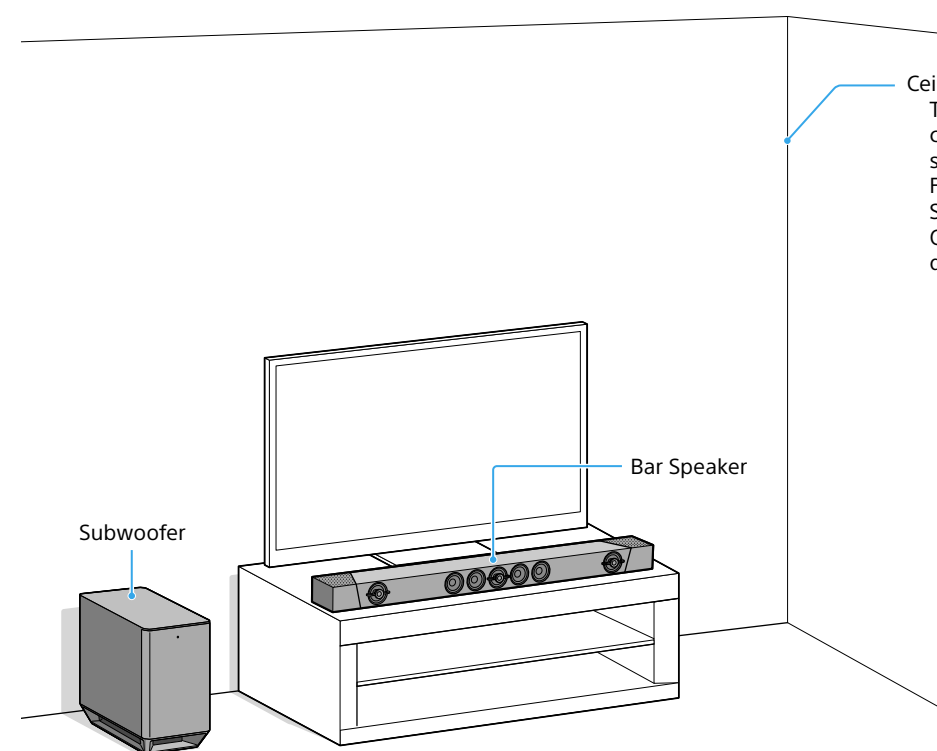

Ceiling height: 14 ft or less (4.3 meters or less)  
To obtain the good surround sound, set the ceiling height of the room where the system is installed.  
For details, see "Customizing the Speaker Settings for Surround Sound" in the Operating Instructions (separate document).

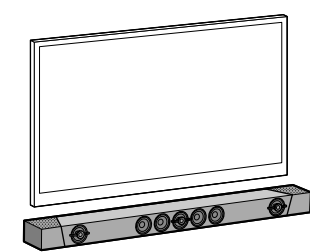

**To mount the Bar Speaker on a wall**  
Refer to "Mounting the Main Unit on a Wall" in the Operating Instructions (separate document).

- Note**
- Do not place magnetic cards on the system or near the system.
  - Do not place metal objects other than a TV around the system. Wireless functions may become unstable.

2 Connecting with a TV and other devices

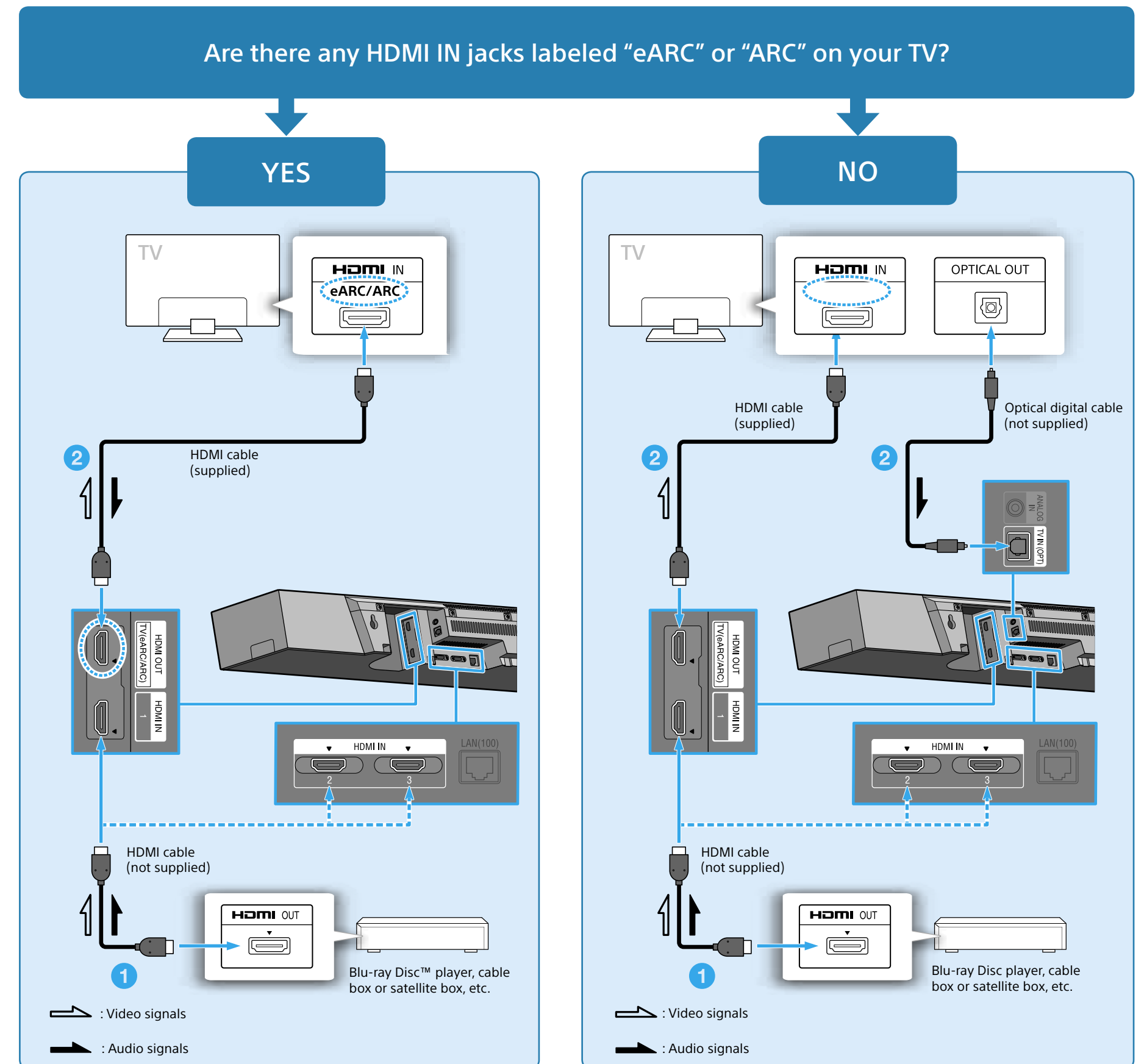

- Connect devices such as a Blu-ray Disc player, cable box, or satellite box to any of the HDMI IN jacks (HDMI1/2/3) on the Bar Speaker. When devices such as a Blu-ray Disc player, cable box, or satellite box are currently connected to a TV, disconnect them from the TV and then connect them to the Bar Speaker to reproduce the high quality surround sound of Dolby Atmos, Dolby TrueHD, Dolby Digital Plus.
- Connect a TV to the HDMI OUT jack on the Bar Speaker. When your TV does not have an HDMI IN jack labeled "eARC" or "ARC," also connect the TV to the TV IN (OPT) jack on the Bar Speaker.

- Tip**
- The Standby Through function allows you to output HDMI signals to the TV even when the system is in standby mode. Adjust the setting as follows: Press HOME → [Setup] → [System Settings] → [HDMI Settings] → [Standby Through], then select [Auto] or [On].
  - When your TV does not have both an OPTICAL OUT jack and an HDMI IN jack, refer to "Connecting a TV or Portable Audio Device via the ANALOG IN Jack" in the Operating Instructions (separate document) for a connection method.
- Note**
- Make sure that the cables are firmly inserted.
  - To watch 4K video content, refer to "Connecting a 4K TV and 4K Devices" in the Operating Instructions (separate document).



## 3 Setting up the remote control

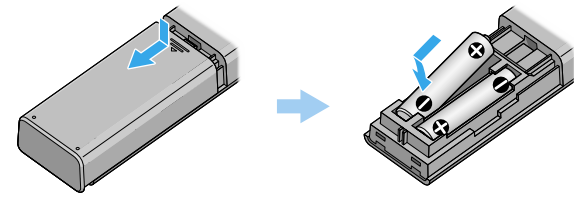

## 4 Turning on the TV

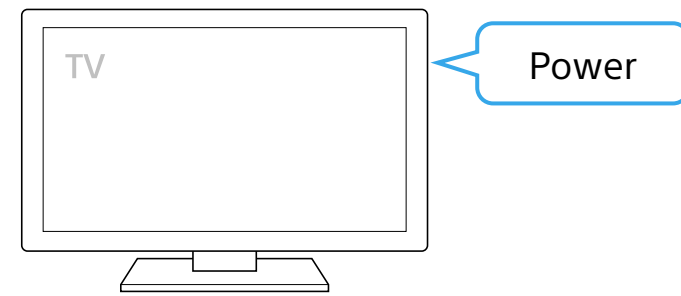

## 5 Turning on the system

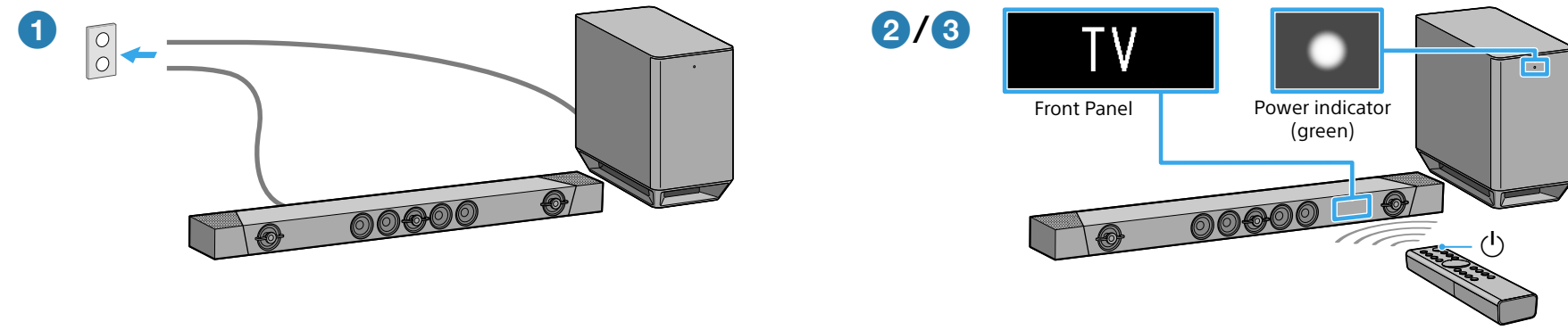

- 1 Connect the AC power cords (mains leads) of the Bar Speaker and subwoofer.
- 2 Press (power) on the remote control of the system.  
The front panel display lights up.
- 3 Confirm that the power indicator of the subwoofer is lit in green.  
If not, refer to "Subwoofer" of "Troubleshooting" in the Operating Instructions (separate document).
- 4 Turn on the connected device.

## 6 Performing Easy Setup

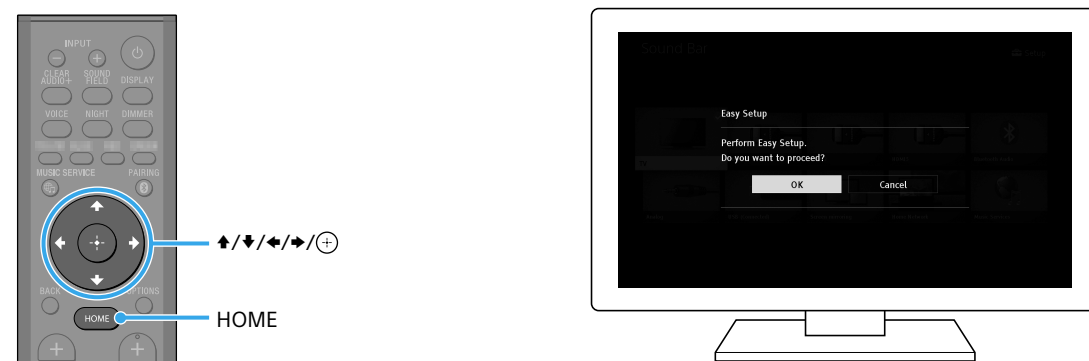

- 1 Press HOME on the remote control of the system.  
The Easy Setup screen is displayed on the TV screen.  
If the Easy Setup screen does not appear, use the remote control of the TV to switch the TV input to that for the HDMI IN jack to which the system is connected.
- 2 Press to select an item as instructed on the TV screen, and then press to perform Easy Setup.
- 3 Once [Easy Initial Settings are complete.] appears, select [Finish].

- Tip**
- On-screen instructions are displayed in the language you selected in this step.
  - For details on the network connection, refer to "Listening to Music/Sound Using the Network Function" in the Operating Instructions (separate document).
  - For details on Chromecast built-in, refer to "Using Chromecast built-in" in the Operating Instructions (separate document).

## 7 Listening to the sound



### To listen to the audio of the TV

- 1 Select the desired program using the remote control of the TV.  
The screen switches to the television broadcast screen and the TV audio is output from the system.  
If the sound of the TV does not output from the system, press INPUT +/- on the remote control of the system until "TV" appears in the front panel.
- 2 Adjust the volume.  
Adjust the volume by pressing on the remote control of the system.  
Adjust the volume of the subwoofer by pressing SW on the remote control of the system.  
For details on the sound quality adjustment, refer to "Selecting the Sound Effect" in the Operating Instructions (separate document).

### To enjoy an input device other than the TV

- 1 Press HOME.  
The home menu appears on the TV screen.  
If the home menu does not appear, use the remote control of the TV to switch the TV input to that for the HDMI IN jack to which the system is connected.
  - 2 Press to select the desired input on the home menu, and then press .
- For details, refer to "About the Home Menu" in the Operating Instructions (separate document).

Setup completed! Enjoy!

Refer to the Operating Instructions (separate document) for what you can do with the system and the network settings.

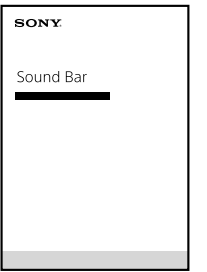

### Troubleshooting

#### No TV sound is output from the system, or no picture is displayed on the TV.

- Press INPUT +/- on the remote control of the system repeatedly until "TV" appears in the front panel display on the system.
- Make sure that the input and output of the HDMI jacks on the system are correct.
- Disconnect the cables that are connected between the TV and the system, then connect them firmly again. Disconnect the AC power cords of the TV and the system from the AC outlets (mains), then connect them again.
- Depending on the order in which you turn on the TV and the system, the system may enter muting mode and "Muting" may appear in the front panel display. In this case, turn on the TV first, then the system.
- When the TV and the system are connected via an HDMI cable, enable the control for HDMI function on the TV. For details on the TV's settings, refer to the operating instructions supplied with the TV. For more information about the control for HDMI function, refer to the Operating Instructions (separate document).
- Check the sound setting of the TV. When the TV is set to output the sound from the TV speakers, change the setting to output the sound from the external speakers.

#### No picture or sound from the device connected to the system is output.

- Press INPUT +/- on the remote control of the system repeatedly until the input connecting the desired device appears on the front panel display of the system.
- Make sure that the input and output of the HDMI jacks on the system are correct.
- Disconnect the cables connected to the system, and then connect them again. Make sure that the cables are firmly inserted.

#### The TV remote control does not work.

- When the Bar Speaker obstructs the remote control sensor of the TV, the TV remote control may not work. In that case, set [IR-Repeater] to [On]. You can control the TV with the remote control of the TV. For details, refer to "Sending the Remote Signal to the TV via the Main Unit" in the Operating Instructions (separate document).

#### No sound or only a very low-level sound is heard from the subwoofer.

- Press SW on the remote control of the system to increase the volume of the subwoofer.

If the problem is not solved even though you have tried the measures above, refer to "Troubleshooting" in the Operating Instructions (separate document).